



บริษัท บีเคอี คอมบัสชั่น คอนโทรลส์ จำกัด

32 ถ.ป่าขาม ต.หัวเวียง อ.เมือง จ.ลำปาง 52000 โทร. 054-315380, 218592 โทรสาร 054-223152

Website <http://www.bkeinter.com>, e-mail: contact@bke.co.th

Open Biogas Flare Technical Data

Model 20BF , 50BF and 100 BF

Type of flare	:	Open Flare
Maximum Capacity	:	20 cu.m/hr, 50 cu.m/hr or 100 cu.m/hr depends on each type of product
Operating pressure	:	15-50 mBar
Ignition System	:	14,000 Volt European Standard Ignition Transformer
Safety Shut-Off Valve	:	1" European Standard EN161 Safety Shut-Off Solenoid Valve
Back Fire Prevention	:	End of line stainless steel flame arrester
Flare Material	:	Stainless Steel
Control Panel	:	Stainless Steel with IP65 lamps and buttons
Start/Stop Sequence	:	Start automatically when biogas pressure at biogas source reaching upper set-point and vice versa stop when reaching the lower set-point
Power supply	:	220 Volt, Single Phase,50Hz
Height	:	2.9 m for 20 cu.m/hr and 50 cu.m/hr types 2.4 m for 100 cu.m/hr type
Alarm signal	:	Lockout(flame out) alarm When flare needs flame.
Flame Detector	:	Flame ionization Detector(FID)
Water removal	:	Automatic Drain

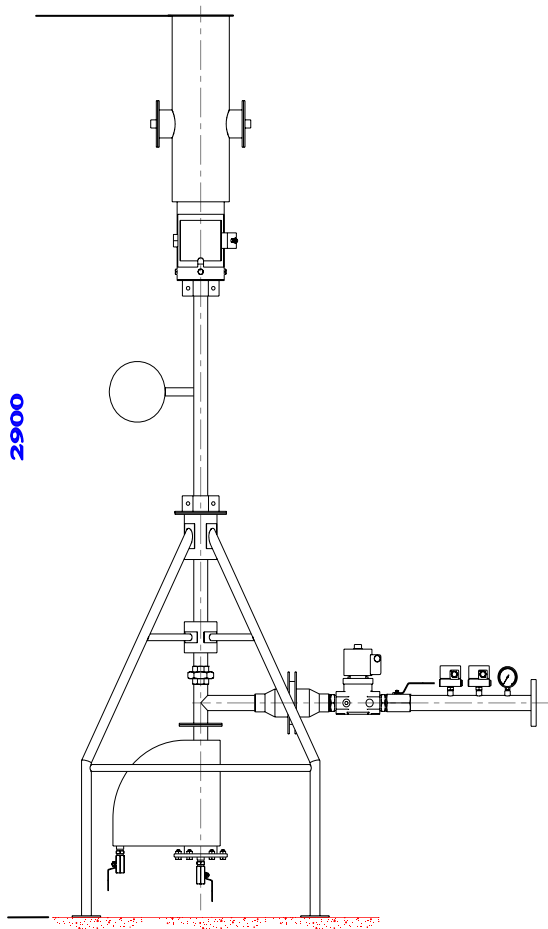

Model 20BF and 50BF

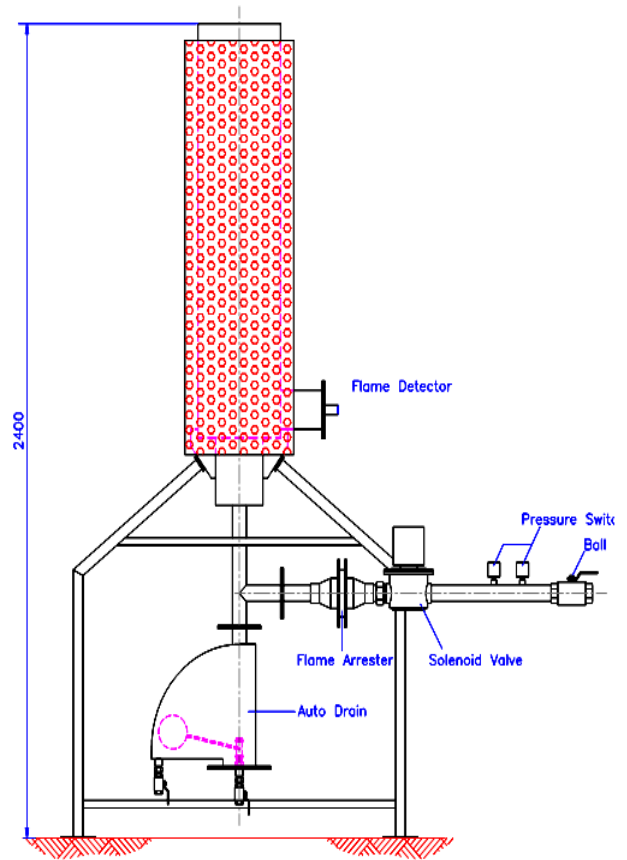

Model 100 BF

Model	Capacity (m ³ /hr)	Height (m)	Working Pressure (mbar)	Voltage
20BF	20	2.90	30/250	220/380
50BF	50	2.90	30/250	220/380
100BF	100	2.40	30/250	220/380

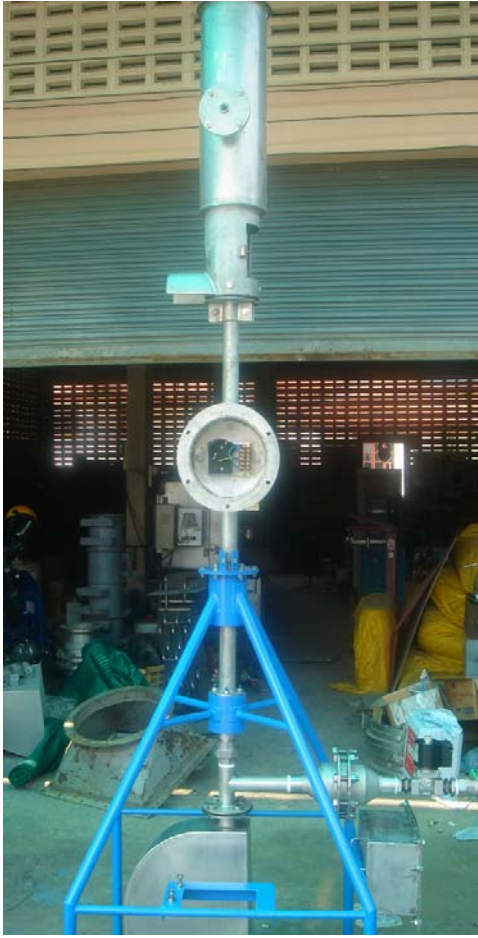

Model 20BF and 50BF



Model 100 BF